

LINOVECTOR II

LV3-S11 14
Copper/Aluminum and
Steel Element Ratings

Submittal

Specification

LV3 Slip Jointed Enclosure

ENCLOSURE:

STYLE: Slope Top, Slope Outlet
OUTLET: Stamped Louvers
Pencil Proof

LENGTHS: 2'0" thru 8'0" in 6" Increments

MAT'L: 18 Ga. CRS (Std)
 16 Ga. CRS (Opt'l)
 14 Ga. CRS (Opt'l)
 18 Ga. Stainless Steel (Opt'l)
 16 Ga. Stainless Steel (Opt'l)
 14 Ga. Stainless Steel (Opt'l)
 16 Ga. Aluminum (Opt'l)
 14 Ga. Aluminum (Opt'l)
 12 Ga. Aluminum (Opt'l)

HEIGHT: 11"
 14"

FINISH: Baked Powder (Std)
 Baked Metallic (Opt'l)

ELEMENT:

TYPE: Cu/AL (Mechanically Expanded)
LENGTHS: 2'0" thru 12'6" in 1" Increments for 1' & 1-1/4' Cu.
2'0" thru 8'0" in 1" Increments for 3/4" Cu.

TYPE: IPS Steel (Mechanically Expanded)
LENGTHS: 2'0" thru 12'6" in 1' Increments
 NPT Thread both Ends (Std)
 Beveled Ends for Field Weld (Opt'l)

See Catalog for Working Pressures

BACKPLATE:

TYPE: Partial B/P
LENGTHS: 8'0" Only
MAT'L: 20 Ga. Prepainted (Std)
 18 Ga. Galvannealed (Opt'l)

TYPE: Full Ht. B/P (Opt'l)
LENGTHS: 2'0" thru 8'0" in 6" Increments
MAT'L: 20 Ga. Galvannealed (Opt'l)
 20 Ga. Painted (Opt'l)
 18 Ga. Painted (Opt'l)

AIRSEAL:

1/8" x 3/8" Closed Cell (Opt'l)

BRACKETS:

Water Brkt w/B.B.
 Steam Brkt w/Brkt Mtd B.B. Hgr (14" Only)

DAMPER:

Damper Blades Factory Installed
 Knob Damper (Opt'l)
 Tamper Resistant (Opt'l)

ACCESSORIES:

LV Overlapping Type

All accessories return to the wall at the bottom and have pre-punched holes for fastening to the wall.

LV3-S11*

ELEMENT TUBE SIZE	FIN SIZE HEIGHT x WIDTH	CRADLE NUMBER	A
3/4 COPPER	3 1/4 x 3 1/4	2	7"
1" COPPER	3 1/4 x 3 1/4	2	7 3/16"
1 1/4 COPPER	3 1/4 x 3 1/4	1	6 5/8"
1" STEEL	3 1/4 x 3 1/4	2	7 5/16"
1 1/4 STEEL	3 1/4 x 3 1/4	1	6 13/16"

*Not recommended for steam applications.

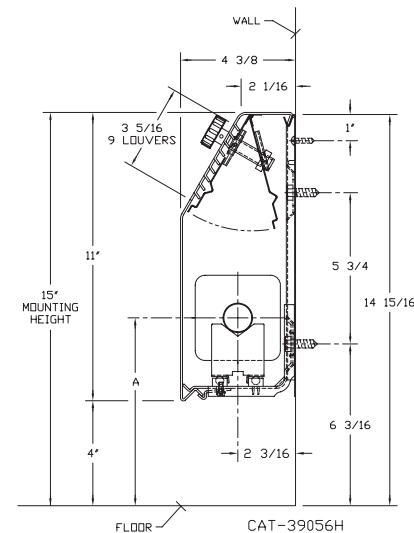

LV3-S14

ELEMENT TUBE SIZE	FIN SIZE HEIGHT x WIDTH	CRADLE NUMBER	A
3/4 COPPER	3 1/4 x 3 1/4	2	7"
1" COPPER	3 1/4 x 3 1/4	2	7 3/16"
1 1/4 COPPER	3 1/4 x 3 1/4	1	6 5/8"
1" STEEL	3 1/4 x 3 1/4	2	7 5/16"
1 1/4 STEEL	3 1/4 x 3 1/4	1	6 13/16"

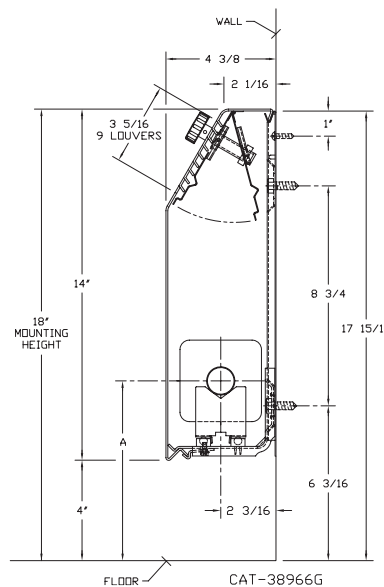

Vulcan

RADIATOR

260 North Elm St., Westfield, MA 01085
(413) 568-9571 Fax: (413) 564-5661
www.vulcanrad.com

PROJECT: _____ DATE: _____

LOCATION: _____

ARCHITECT: _____

ENGINEER: _____

CONTRACTOR: _____

PO NUMBER: _____

STYLE "LV3-S11 14" LINOVECTOR II

COPPER/ALUMINUM ELEMENTS

ALL RATINGS ARE IN BTU/HR/LIN FT AND BASED ON 3 FPS VELOCITY, 65° EAT

TUBE SIZE	CATALOG DESIGNATION	FIN SIZE HEIGHT X WIDTH	FINS PER FT.	FIN THICKNESS IN INCHES	ENCL HEIGHT IN INCHES	TIERS AND CENTERS IN INCHES	MOUNTING HEIGHT IN INCHES	STEAM 215° FACTOR	HOT WATER (AVG.)								
									200°	190°	180°	170°	160°	150°	140°	130°	120°
									CORRECTION FACTORS FOR AVERAGE WATER TEMPERATURES								
3/4"	VC3/4-33	3-1/4" SQ.	32	.020	11*	1	15	1000	860	780	690	610	530	450	400	330	260
3/4"	VC3/4-34	3-1/4" SQ.	40	.020	11*	1	14	1180	1010	920	810	720	630	530	470	390	310
3/4"	VC3/4-35	3-1/4" SQ.	50	.020	11*	1	15	1320	1140	1030	910	810	700	590	530	440	340
1"	VC33	3-1/4" SQ.	32	.020	11*	1	15	980	840	760	680	600	520	440	390	320	250
1"	VC34	3-1/4" SQ.	40	.020	11*	1	15	1150	990	900	790	700	610	520	460	380	300
1"	VC35	3-1/4" SQ.	50	.020	11*	1	15	1260	1080	980	870	770	670	570	500	420	330
1 1/4"	VC133	3-1/4" SQ.	32	.020	11*	1	15	920	790	720	630	560	490	410	370	300	240
1 1/4"	VC134	3-1/4" SQ.	40	.020	11*	1	15	1080	930	840	750	660	570	490	430	360	280
1 1/4"	VC135	3-1/4" SQ.	50	.020	11*	1	15	1190	1020	930	820	730	630	540	480	390	310
3/4"	VC3/4-33	3-1/4" SQ.	32	.020	14	1	18	1080	930	840	750	660	570	490	430	360	280
3/4"	VC3/4-34	3-1/4" SQ.	40	.020	14	1	18	1290	1110	1010	890	790	680	580	520	430	340
3/4"	VC3/4-35	3-1/4" SQ.	50	.020	14	1	18	1440	1240	1120	990	880	760	650	580	480	370
1"	VC33	3-1/4" SQ.	32	.020	14	1	18	1060	910	830	730	650	560	480	420	350	280
1"	VC34	3-1/4" SQ.	40	.020	14	1	18	1250	1080	980	860	760	660	560	500	410	330
1"	VC35	3-1/4" SQ.	50	.020	14	1	18	1370	1180	1070	950	840	730	620	550	450	360
1 1/4"	VC133	3-1/4" SQ.	32	.020	14	1	18	1020	880	800	700	620	540	460	410	340	270
1 1/4"	VC134	3-1/4" SQ.	40	.020	14	1	18	1190	1020	930	820	730	630	540	480	390	310
1 1/4"	VC135	3-1/4" SQ.	50	.020	14	1	18	1330	1140	1040	920	810	700	600	530	440	350

*Not recommended for steam applications consult factory.

Note: Copper tube furnished flared one end standard.

STEEL ELEMENTS

ALL RATINGS ARE IN BTU/HR/LIN FT AND BASED ON 3 FPS VELOCITY, 65° EAT

TUBE SIZE	CATALOG DESIGNATION	FIN SIZE HEIGHT X WIDTH	FINS PER FT.	FIN THICKNESS IN INCHES	ENCL HEIGHT IN INCHES	TIERS AND CENTERS IN INCHES	MOUNTING HEIGHT IN INCHES	STEAM 215° FACTOR	HOT WATER (AVG.)								
									200°	190°	180°	170°	160°	150°	140°	130°	120°
									CORRECTION FACTORS FOR AVERAGE WATER TEMPERATURES								
1"	VS33	3-1/4" SQ.	32	.032	11*	1	15	930	800	730	640	570	490	420	370	310	240
1"	VS34	3-1/4" SQ.	40	.032	11*	1	15	990	850	770	680	600	520	450	400	330	260
1"	VS35	3-1/4" SQ.	50	.032	11*	1	15	1080	930	840	750	660	570	490	430	360	280
1-1/4"	VS133	3-1/4" SQ.	32	.032	11*	1	15	920	790	720	630	560	490	410	370	300	240
1-1/4"	VS134	3-1/4" SQ.	40	.032	11*	1	15	1000	860	780	690	610	530	450	400	330	260
1-1/4"	VS135	3-1/4" SQ.	50	.032	11*	1	15	1050	900	820	720	640	560	470	420	350	270
1"	VS33	3-1/4" SQ.	32	.032	14	1	18	970	830	760	670	590	510	440	390	320	250
1"	VS34	3-1/4" SQ.	40	.032	14	1	18	1110	950	870	770	680	590	500	440	370	290
1"	VS35	3-1/4" SQ.	50	.032	14	1	18	1180	1010	920	810	720	630	530	470	390	310
1-1/4"	VS133	3-1/4" SQ.	32	.032	14	1	18	960	830	750	660	590	510	430	380	320	250
1-1/4"	VS134	3-1/4" SQ.	40	.032	14	1	18	1120	960	870	770	680	590	500	450	370	290
1-1/4"	VS135	3-1/4" SQ.	50	.032	14	1	18	1150	990	900	790	700	610	520	460	380	300

*Not recommended for steam applications consult factory.

Notes: 1) Steel fins furnished as .032 thick, painted black.

2) NPT threads furnished on steel elements. Please use domestic fittings for proper installation.

3) The ends can be provided chamfered for field welded fittings when specified.

Steam Bracket and BB Hanger

ELEMENT TUBE SIZE	FIN SIZE HEIGHT x WIDTH	CRADLE NUMBER	A MIN	A MAX
3/4 COPPER	3 1/4 x 3 1/4	2	7 3/8	9 5/8
1" COPPER	3 1/4 x 3 1/4	2	7 1/2	9 3/4
1 1/4 COPPER	3 1/4 x 3 1/4	2	7 5/8	9 7/8
1" STEEL	3 1/4 x 3 1/4	2	7 5/8	9 3/4
1 1/4 STEEL	3 1/4 x 3 1/4	1	7 3/16	9 3/8

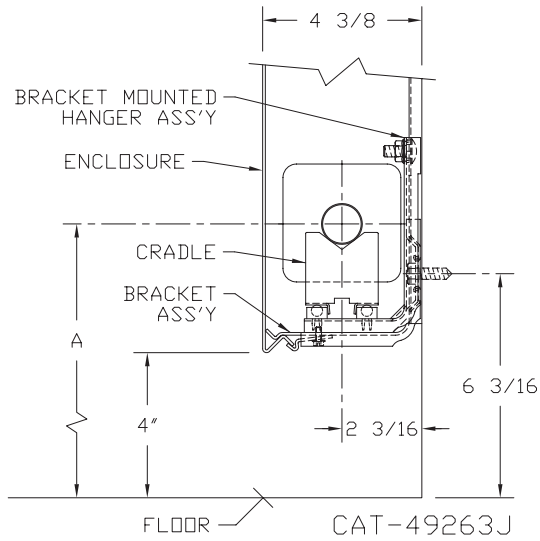

Design Data

COMMERCIAL FINNED TUBE CHARTS FOR RATING CORRECTIONS

For assistance with ratings and selection, please use our online Specifier.

CORRECTION FACTORS FOR WATER TEMPERATURES AND AIR TEMPERATURES OTHER THAN STANDARD															
AVERAGE WATER TEMP. °F	ENTERING AIR TEMPERATURE °F														
	45	55	STD 65	70	75	80	85	90	95	100	110	120	130	140	150
90	.19	.13	.11	.06											
100	.25	.19	.15	.11	.08	.06									
110	.31	.25	.20	.16	.13	.11	.08	.06							
120	.38	.31	.26	.21	.19	.16	.13	.11	.08	.06					
130	.45	.38	.33	.28	.25	.21	.19	.16	.13	.11	.06				
140	.53	.45	.40	.34	.31	.28	.25	.21	.19	.16	.11	.06			
150	.61	.53	.45	.41	.38	.34	.31	.28	.25	.21	.16	.11	.06		
160	.69	.61	.53	.49	.45	.41	.38	.34	.31	.28	.21	.16	.11	.06	
170	.77	.69	.61	.57	.53	.49	.45	.41	.38	.34	.28	.21	.16	.11	.06
180	.86	.77	.69	.65	.61	.57	.53	.49	.45	.41	.34	.28	.21	.16	.11
190	.95	.86	.78	.73	.69	.65	.61	.57	.53	.49	.41	.34	.28	.21	.16
200	1.05	.95	.86	.82	.77	.73	.69	.65	.61	.57	.49	.41	.34	.28	.21
210	1.14	1.05	.95	.91	.86	.82	.77	.73	.69	.65	.57	.49	.41	.34	.28
▶ 215 (STD.)	1.19	1.09	1.00	.95	.91	.86	.82	.77	.73	.69	.61	.53	.45	.38	.31
220	1.24	1.14	1.05	1.00	.95	.91	.86	.82	.77	.73	.65	.57	.49	.41	.34
230	1.34	1.24	1.14	1.09	1.05	1.00	.95	.91	.86	.82	.73	.65	.57	.49	.41
240	1.44	1.34	1.25	1.19	1.14	1.09	1.05	1.00	.95	.91	.82	.73	.65	.57	.49
250	1.55	1.44	1.34	1.29	1.24	1.19	1.14	1.09	1.05	1.00	.91	.82	.73	.65	.57
260	1.66	1.55	1.44	1.39	1.34	1.29	1.24	1.19	1.14	1.09	1.00	.91	.82	.73	.65
270	1.76	1.66	1.55	1.50	1.44	1.39	1.34	1.29	1.24	1.19	1.09	1.00	.91	.82	.73
280	1.87	1.76	1.66	1.60	1.55	1.50	1.44	1.39	1.34	1.29	1.19	1.09	1.00	.91	.82
290	1.99	1.87	1.76	1.71	1.66	1.60	1.55	1.50	1.44	1.39	1.29	1.19	1.09	1.00	.91
300	2.10	1.99	1.87	1.82	1.76	1.71	1.66	1.60	1.55	1.50	1.39	1.29	1.19	1.09	1.00

CORRECTION FACTORS FOR STEAM PRESSURES AND AIR TEMPERATURES OTHER THAN STANDARD																
STEAM		ENTERING AIR TEMPERATURE °F														
PRESSURE		TEMP. °F	45	55	STD 65	70	75	80	85	90	100	110	120	130	140	150
GAUGE	ABS. PSI															
(VAC) 15" HG	7.32	178.9	0.90	0.80	0.70	0.65	0.60	0.56	0.51	0.45	0.39	0.32	0.25	0.18	0.13	0.08
(VAC) 10"	9.78	192.2	1.02	0.91	0.81	0.76	0.71	0.66	0.62	0.55	0.48	0.40	0.33	0.26	0.20	0.14
(VAC) 5"	12.25	202.9	1.11	1.00	0.90	0.85	0.79	0.75	0.70	0.63	0.56	0.48	0.40	0.33	0.27	0.20
▶ 0 PSI	14.696	212.0	1.19	1.09	0.97	0.92	0.87	0.82	0.77	0.70	0.63	0.54	0.46	0.38	0.31	0.25
.899	15.595	215.0	1.22	1.11	1.00	0.95	0.90	0.84	0.80	0.75	0.65	0.57	0.48	0.40	0.33	0.26
5	19.70	227.1	1.34	1.22	1.11	1.05	1.00	0.95	0.90	0.81	0.75	0.66	0.57	0.49	0.41	0.34
10	24.70	239.4	1.45	1.33	1.22	1.17	1.11	1.05	1.00	0.91	0.85	0.75	0.66	0.58	0.50	0.42
15	29.70	249.8	1.55	1.43	1.31	1.26	1.20	1.14	1.09	1.00	0.94	0.84	0.75	0.66	0.57	0.49
20	34.70	258.5	1.63	1.52	1.40	1.33	1.28	1.23	1.17	1.07	1.02	0.92	0.82	0.73	0.64	0.55
25	39.70	266.8	1.71	1.59	1.47	1.41	1.36	1.30	1.25	1.15	1.09	0.98	0.89	0.80	0.71	0.62
30	44.70	274.0	1.78	1.66	1.54	1.48	1.42	1.37	1.31	1.21	1.15	1.05	0.95	0.85	0.76	0.68
40	54.70	286.7	1.91	1.79	1.66	1.61	1.54	1.49	1.43	1.32	1.27	1.16	1.06	0.97	0.87	0.78
50	64.70	297.7	2.02	1.90	1.77	1.71	1.65	1.60	1.54	1.42	1.37	1.26	1.16	1.06	0.96	0.87
60	74.70	307.3	2.10	2.00	1.87	1.81	1.75	1.69	1.63	1.51	1.47	1.35	1.25	1.15	1.05	0.95
70	84.70	316.0	2.20	2.09	1.95	1.89	1.83	1.77	1.71	1.59	1.55	1.44	1.33	1.23	1.12	1.03
80	94.70	323.9	2.27	2.17	2.03	1.97	1.91	1.85	1.80	1.69	1.63	1.52	1.41	1.31	1.20	1.10
90	104.70	331.2	2.36	2.24	2.11	2.05	1.98	1.93	1.87	1.74	1.70	1.59	1.48	1.38	1.28	1.17
100	114.70	337.9	2.43	2.31	2.18	2.11	2.05	2.00	1.94	1.81	1.77	1.65	1.54	1.44	1.33	1.23
125	139.70	352.9	2.59	2.47	2.33	2.27	2.21	2.16	2.10	1.96	1.92	1.80	1.69	1.59	1.48	1.38
150	164.70	365.9	2.73	2.62	2.47	2.43	2.35	2.29	2.23	2.08	2.05	1.94	1.82	1.72	1.61	1.51
175	189.70	377.4	2.86	2.74	2.60	2.54	2.47	2.41	2.35	2.21	2.17	2.05	1.95	1.85	1.73	1.63
200	214.70	387.8	2.95	2.85	2.71	2.63	2.58	2.52	2.47	2.31	2.29	2.17	2.06	1.96	1.84	1.75

From Keenan and Keyes — Linear Interpolation. NOTE: Gauge pressure should be corrected for altitude.

Rate of pitch for steam ½" drop over 20-foot run.

Design Data

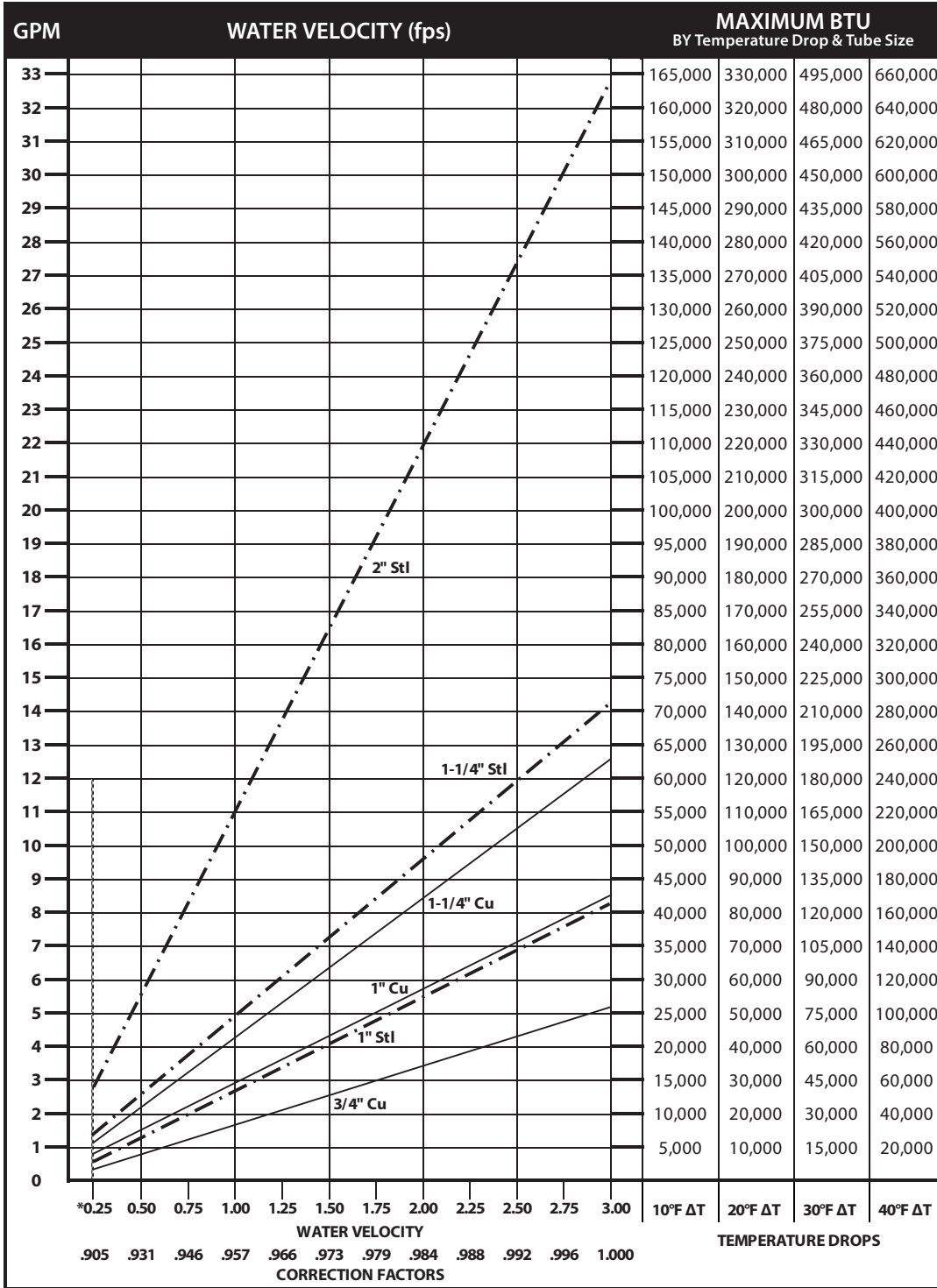

*Do not design below .25 fps.

DYNAMIC FORMULAS

$$BTU = GPM \times 500 \times TD$$

$$GPM = \left(\frac{BTU}{500} \right) \div TD$$

$$TD = \left(\frac{BTU}{500} \right) \div GPM$$

Pressure Drop at Given Water Velocities (Feet of Water per 100 ft. of pipe) based on Hazen - Williams calculation

Nominal Pipe Size	Water Velocity (ft/sec)											
	0.25	0.50	0.75	1.00	1.25	1.50	1.75	2.00	2.25	2.50	2.75	3.00
3/4" Copper	0.06	0.20	0.42	0.72	1.09	1.53	2.04	2.61	3.25	3.95	4.71	5.53
1" Copper	0.04	0.15	0.32	0.54	0.81	1.14	1.52	1.94	2.42	2.94	3.50	4.11
1 1/4" Copper	0.03	0.12	0.25	0.43	0.64	0.90	1.20	1.54	1.92	2.33	2.78	3.26
1" Steel	0.04	0.15	0.32	0.54	0.81	1.14	1.52	1.95	2.42	2.94	3.51	4.12
1 1/4" Steel	0.03	0.11	0.23	0.40	0.60	0.84	1.12	1.44	1.79	2.17	2.59	3.05
2" Steel	0.02	0.07	0.14	0.25	0.37	0.52	0.69	0.89	1.10	1.34	1.60	1.88

Design Data

GUARANTEED WORKING PRESSURES

- 1" IPS — 780 at Temperatures up to 650°F.
- 1-1/4" IPS — 660 at Temperatures up to 650°F.
- 2" IPS — 405 at Temperatures up to 650°F.
- 1-1/4" CU — 194 at Temperatures up to 300°F.
- 1" CU 204 at Temperatures up to 300°F.
- 3/4" CU 218 PSI at Temperatures up to 300°F.

MAXIMUM PRESSURES AT OTHER TEMPERATURES ARE AVAILABLE UPON REQUEST.

Pipe Water Capacities and Quantities Circulated at Velocity of 3 Feet Per Second

Nominal Pipe Size	Pipe I.D. (inches)	Gals Per Lin. Ft.	GPM @ 3' per sec Velocity
3/4" Copper	0.835	0.028	5.12
1" Copper	1.077	0.047	8.52
1 1/4" Copper	1.315	0.071	12.70
1" Steel	1.075	0.047	8.49
1 1/4" Steel	1.395	0.079	14.29
2" Steel	2.115	0.183	32.85

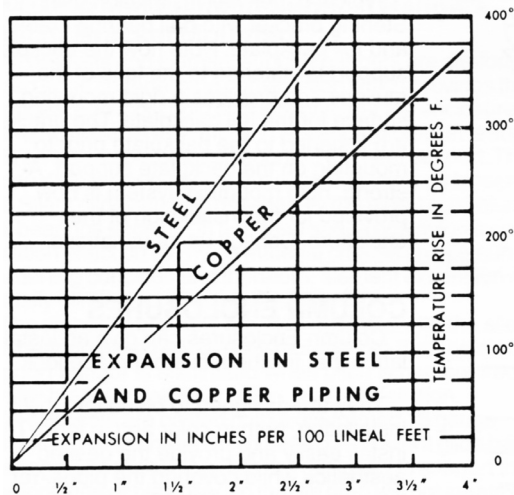

Glycol Correction Factors

Fluid Temperature 200°F

% Solution	Ethylene Glycol	Propylene Glycol
20	.952	.988
30	.921	.968
40	.888	.943
50	.852	.912

Fluid Temperature 180°F

% Solution	Ethylene Glycol	Propylene Glycol
20	.946	.982
30	.913	.961
40	.879	.934
50	.842	.902

Fluid Temperature 140°F

% Solution	Ethylene Glycol	Propylene Glycol
20	.934	.97
30	.898	.946
40	.861	.916
50	.821	.881

INLET VS. OUTPUT/BTUH CAPACITY REDUCTION

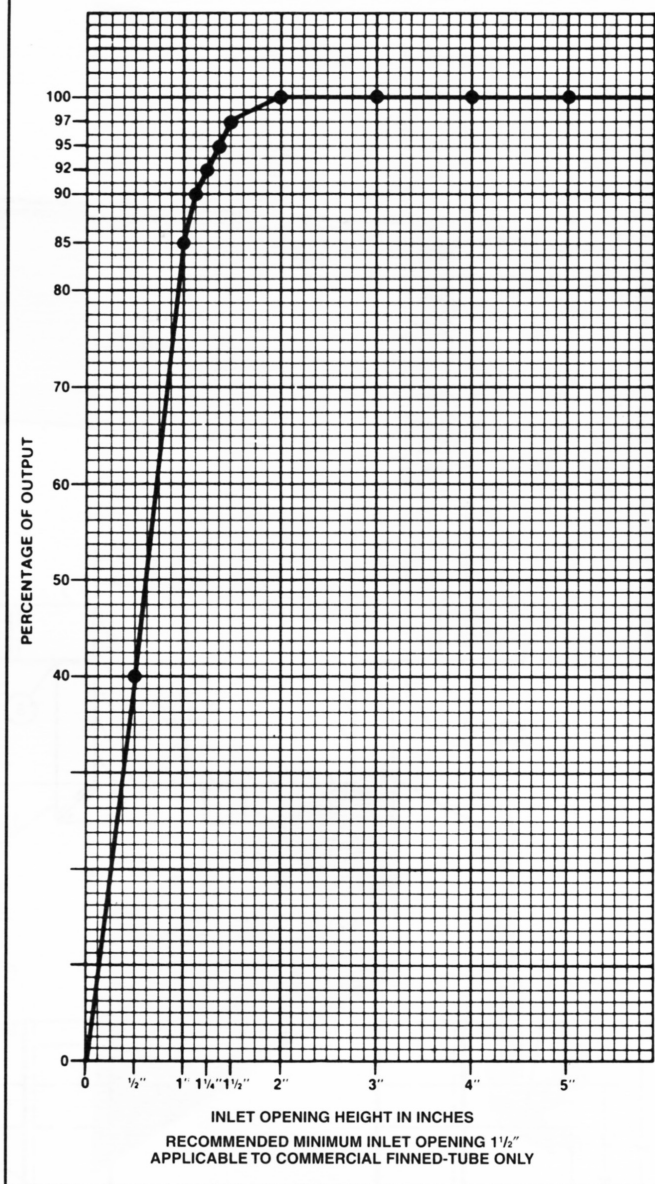

INLET OPENING HEIGHT IN INCHES

RECOMMENDED MINIMUM INLET OPENING 1/2" APPLICABLE TO COMMERCIAL FINNED-TUBE ONLY

ALTITUDE FACTORS

Approximate factors for convective heat value at varying altitudes

Altitude	Ferrous Units	Copper Alum. Units
Sea Level	1.000	1.000
1,000 ft.	.984	.969
2,000 ft.	.968	.938
3,000 ft.	.952	.908
4,000 ft.	.936	.878
5,000 ft.	.920	.850
6,000 ft.	.904	.822
7,000 ft.	.889	.795
8,000 ft.	.874	.768
9,000 ft.	.859	.743
10,000 ft.	.844	.718
15,000 ft.	.771	.603
20,000 ft.	.703	.502